

O₂ MEASUREMENT IN THE LAB

OXYTRANS M continuously measures the content of oxygen in liquids and gases. The lightweight portable instrument can easily be connected with hoses. It perfectly meets the requirements for measuring O₂ content with high precision in any laboratory environment. OXYTRANS M covers a measurement range from 1 ppb to 50 ppm (liquid phase) and from 0 to 50 % (gas phase). It can be applied for temperatures up to +98 °C and is supplied with PC software and USB-interface. The automatic datalog feature is very useful for occasional process monitoring and fault finding.



Innovation. Dedication. Centec.

Germany
Centec GmbH
Wilhelm-Röntgen-Strasse 10
63477 Maintal
Tel.: +49 6181 18 78 0
Fax: +49 6181 18 78 50
info@centec.de

Czech Republic
Centec automatika s.r.o.
Pekařská 8/601
155 00 Praha 5
Tel.: +420 257 084 111
Fax: +420 235 518 701
prodej@centec.cz

USA
Centec LLC
P. O. Box 820
Germantown, WI 53022-0820
Tel.: +1 262 251 8209
Fax: +1 262 251 8376
info@centec-usa.com

UK
Centec UK
Stalworths, The Street
Great Tey, Colchester, Essex, CO6 1JS
Tel.: +44 1206 21 19 21
Fax: +44 1206 21 19 16
info@centec-uk.com

Serbia
Centec Serbia
Bogdana Žerajića 34/III
11000 Beograd
Tel.: + 381 11 358 11 24
Fax: + 381 11 358 11 24
info@centec.rs

India
Centec RRR Systems & Sensors Pvt Ltd
RRR House, Plot 80, Sector 23
Turbhe Naka, Navi Mumbai - 400 705
Tel.: +91 22 2783 3655 & 2783 1348
Fax: +91 22 2783 4814
mail@centecrrr.com

Brazil
Centec América Latina Ltda
Rua Mexico 148 conj. 1004 Centro
20031 142 Rio de Janeiro
Tel.: +55 21 2223 2066
centeclatina@terra.com.br

RHOTECL

**Determination of
Concentration by
Density**

Centec Laboratory Sensors

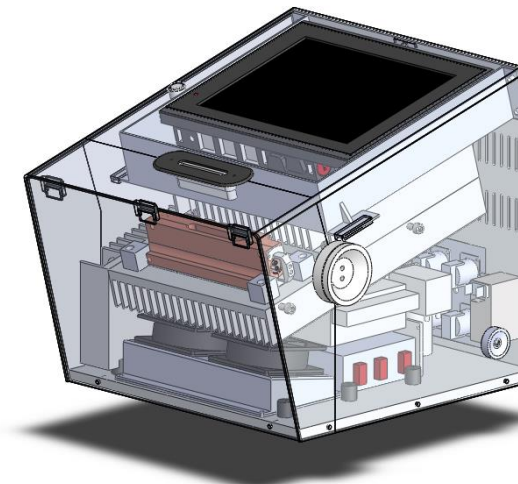

**Automated
process skids
and high precision
sensors from a
single source.
Centec.**

RHOTEC L

The Principle

RHOTEC L continuously measures the density of liquids. Designed for laboratory applications that require maximum sensitivity and high accuracy, this device is ideally suited for extremely small sample volumes. For density measurement, the liquid flows through a U-shaped tube. While the tube is electronically excited to oscillate at resonance, the oscillation frequency is observed. Any change in the fluid density has an impact on the detected signal and can thus be identified. As a specific property of each liquid, the correlation between concentration and density can be described by a mathematical polynomial. With decades of experience and own laboratory facilities, we have a particular knowledge of the polynomials for a huge number of products. Any temperature drifts of the measured signal are automatically compensated for by an internal Pt1000 sensor. RHOTEC L is equipped with a very quick and accurate temperature controller based on Peltier technology. The 10" touch screen, the compatibility of the software and various interfaces for data exchange make RHOTEC L extremely user-friendly. The instrument displays various units, e.g. vol.%, mass %, °Brix and °Plato.



RHOTEC L
Laboratory Density Meter

- **Highly Precise and Fast Determination of the Concentration**
- **Based on Density Measurement with Minimum Sample Volume**
- **Applicable for a Huge Number of Liquids in Various Industries**
- **User-Friendly 10" Touch Screen**
- **Software Compatible with MS Windows® and MS Office®**
- **Various Interfaces (USB, WLAN, Ethernet)**
- **Outstanding Price-Performance-Ratio**

Technical Data **RHOTEC L**

Measuring Range	0 - 3 g/cm ³
Accuracy	± 0,0001 g/cm ³
Repeatability Density	± 0,00005 g/cm ³
Repeatability Temperature	± 0,02 °C
Sample Volume	approx. 2 ml
Measurement Time	30 - 60 s
Temperature of Operation	+5 - + 85 °C
Temperature of Environment	+10 - + 40 °C
Temperature Compensation	Pt1000
Material	glass; PTFE
Connections	nozzles, PTFE
Display	10" touch screen
Interface	USB; WLAN; Ethernet
Housing	aluminum, powder coated
Weight	22 kg
Power Supply	230 VAC